

# HA Table Stand

## Table mount

The table mount HA Table Stand is suitable for single screens with a screen size of 40 - 55" | 102 - 140 cm.

Screens can be mounted in landscape format. The VESA standards up to max. 400 x 400 mm are supported.

The mount can be tilted continuously between +5 and -10° and can also be swiveled ±35°.

**Item no.: 8700**

The height can be varied between 583 and 733 mm using hook-in steps.

Thanks to a clever solution, the cabling disappears inside the table mount.

The max. load is 40 kg.



+5 / -10° tiltable

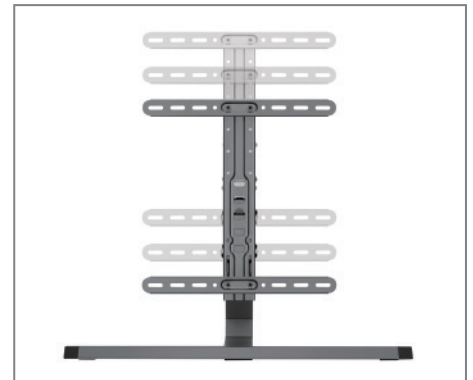

height adjustable



incl. cable routing

## HA Table Stand

### Table mount

Item no.: 8700

- 40 - 55" | 102 - 140 cm
- incl. VESA mount with max. 400 x 400 mm
- landscape format
- +5° / - 10° tiltable
- ±35° swivelling
- height adjustable, min. 583 up to max. 733 mm
- floor space required: width 760 x depth 343 mm
- internal cable routing
- 40 kg max. load
- colour: silver
- optionally also suitable for wall mounting

